



# TR 继电器 Relay

安全、值得信赖

# TAYEE Brand legend

## 关于天逸品牌的传奇

上海天逸电器有限公司自1997年诞生于上海，历经20余年的发展到如今拥有占地面积15000m<sup>2</sup>生产基地、员工超500人的现代化企业。

1997年，第一款产品AD17指示灯问世，采用LED作为光源，成功淘汰了耗能白织灯。

2002年，LA42按钮成为市场明星产品，广泛受到客户认可。

2007年，成为中国主令电器领导品牌

2012年，确立重点四大高端OEM行业

2017年，成为合资企业

创新，高效，一切从客户需求出发催生了天逸的发展，如今，天逸电器拥有六大类产品，50个产品系列，30000余种产品规格。至今为止，天逸服务范围已经覆盖影响中国经济力量的12大重要行业。天逸，正在为中国制造业腾飞贡献着自己的一份力量。



高端品质



灵活稳定



天逸与众多行业的高端品牌长期合作  
所以，天逸更能听懂您真正想要什么

天逸有能力处理众多行业高端品牌的高要求解决方案

所以，天逸更能给您真正想要的



安全可靠

电梯

轨道交通

工程机械

汽车配套

航空航天

新能源

电力

房地产

军工

机床

船舶港口

自动化

专业专注



# 目录 CONTENT

产品结构 ..... 05-07

产品参数 ..... 08-13

产品订货型号 ..... 14-19

附件订货型号 ..... 20-21

尺寸及接线图 ..... 22-27



## TRM 产品结构



继电器



**RCG24/240**  
防浪涌保护插件  
(适用于TRM/TRN/TRC)



**SMG024/120/240**  
防浪涌保护插件  
(适用于TRM/TRN/TRC)



**SDG250**  
防浪涌保护插件  
(适用于TRM/TRN/TRC)



**SCG02**  
金属紧固卡扣  
(适用于混合/分离型基座)



**SCG07**  
金属紧固卡扣  
(适用于优化型基座)



**SCG06**  
塑料紧固卡扣  
(适用于混合/分离型基座)



**SLG02**  
标示牌  
(适用于混合/分离型基座)



优化型插座



分离型插座

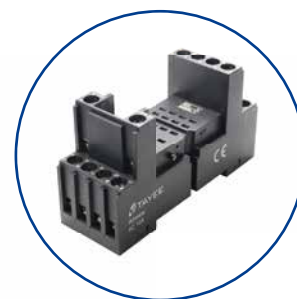

混合型插座

## TRN 产品结构



继电器

**RCG24/240**防浪涌保护插件  
(适用于TRM/TRN/TRC)**SMG024/120/240**防浪涌保护插件  
(适用于TRM/TRN/TRC)**SDG250**防浪涌保护插件  
(适用于TRM/TRN/TRC)**SCG02**金属紧固卡扣  
(适用于混合/分离型基座)**SCG07**金属紧固卡扣  
(适用于优化型基座)**SCG06**塑料紧固卡扣  
(适用于混合/分离型基座)**SLG02**标示牌  
(适用于混合/分离型基座)

优化型插座



分离型插座



混合型插座

## TRC 产品结构



继电器



**RCG24/240**  
防浪涌保护插件  
(适用于TRM/TRN/TRC)



**SMG024/120/240**  
防浪涌保护插件  
(适用于TRM/TRN/TRC)



**SDG250**  
防浪涌保护插件  
(适用于TRM/TRN/TRC)



**TRCSLG01**  
TRC标示牌  
(适用于分离型基座)



**TRCSCG01**  
TRC塑料扳扣  
(适用于分离型基座)



**TRCSQG01**  
TRC连接桥  
(适用于分离型基座)

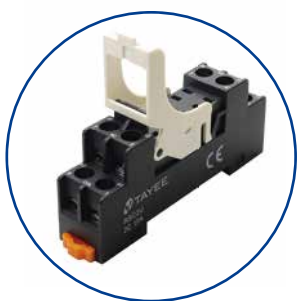

优化型插座



分离型插座

## TRM 产品参数

产品性能				
触点	形式	2C/O	4C/O	
	负载	阻性	12A/250VAC 30VDC	6A/250VAC 30VDC
		马达	1/3HP,240VAC	1/6HP,240VAC
	切换功率 (阻性)	3000VA, 360W	1500VA, 180W	
	接触电阻 (初始)	≤50mΩ		
	材料	Ag alloy		
	电气寿命 (频率 1S 通, 1S 断) 高温	≥10 x 10 <sup>4</sup> 次 (1800 Ops/h)		
	机械寿命	≥1000 x 10 <sup>4</sup> 次 (18000 Ops/h)		
吸合电压 (23)	DC: ≤75% (额定电压), AC: ≤80% 50/60Hz (额定电压)			
释放电压 (23)	DC: ≥10% (额定电压), AC: ≥30% 50/60Hz (额定电压)			
最大电压 (23)	110% (额定电压)			
绝缘电阻	≥1000MΩ			
线圈功率	DC(W)	约 0.9		
	AC(VA)	约 1.2		
吸合时间 (额定电压)	≤20 ms			
释放时间 (额定电压)	≤20 ms			
初始耐压	同极触点之间	1000VAC/1min (漏电流 1mA)		
	异极触点之间	2000VAC/1min (漏电流 1mA)		
	触点与线圈间	2000VAC/1min (漏电流 1mA)		
环境温度	-55~+70°C			
环境湿度	35%~85%RH			
大气压力	86~106KPa			
耐冲击	10G (正弦半波脉冲: 11ms)			
耐振动	10~55Hz 双振幅: 1.0 mm			
安装方式	插入式			
重量	35g			
认证	CE			
符合标准	继电器符合 IEC61810、底座符合 IEC60947			

## 线圈规格 (23°C)

额定电压 V.DC	12	24	48	110
线圈电阻 Ω	180	640	2600	13000
额定电压 V.AC	24	48	115	230
线圈电阻 Ω	180	640	4430	16500

注: 线圈电阻公差: 线圈额定电压标称值 110V 以下 1±10%Ω, 110V 以上 1±15%Ω。



## TRM 产品参数

## 基座参数

型号		RSM2S/RSM2M	RSM4S/RSM4M
额定负载	电流	A	12
	电压	V	300
介质耐压	线圈 / 触点	V/S	4000
	触点间	V/S	2500
螺钉扭矩		Nm	> 0.8
外连接导线		AWG/mm 2	20-14/0.5-2.5
使用环境		°C	-40~+85

## 基座参数

型号		RSM2U	RSM4U
额定负载	电流	A	10
	电压	V	300
介质耐压		V/S	2000
螺钉扭矩		Nm	> 0.8
外连接导线		AWG/mm 2	20-14/0.5-2.5
使用环境		°C	-40~+65

## 性能曲线图

## TRM2

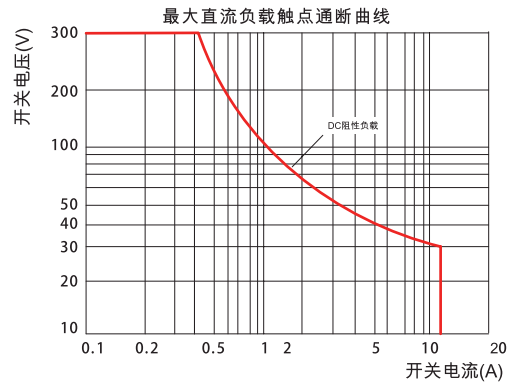
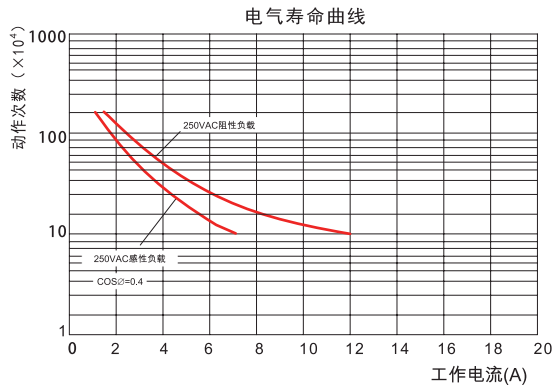

## TRM4

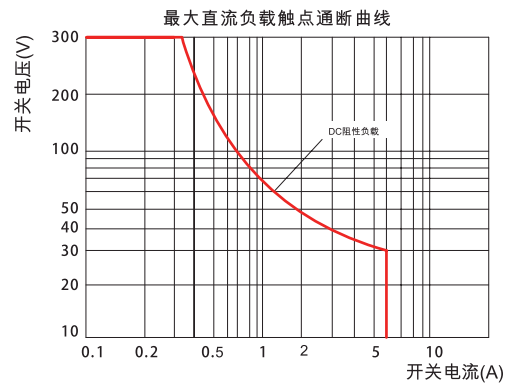
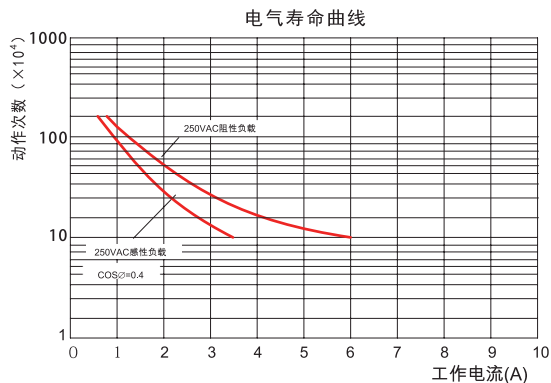

## TRN 产品参数

产品性能				
触点	形式	2C/O	4C/O	
	负载	阻性	5A/250VAC, 30VDC	3A/250VAC, 30VDC
		马达	1/3HP,240VAC	1/6HP,240VAC
	切换功率 (阻性)	1000VA, 150W	750VA, 90W	
	接触电阻 (初始)	≤50mΩ		
	材料	Ag alloy		
	电气寿命 (频率 1S 通, 1S 断) 高温	≥10 x 10 <sup>4</sup> 次 (1800 Ops/h)		
	机械寿命	≥1000 x 10 <sup>4</sup> 次 (18000 Ops/h)		
吸合电压 (23)	DC: ≤75% (额定电压), AC: ≤80% 50/60Hz (额定电压)			
释放电压 (23)	DC: ≥10% (额定电压), AC: ≥30% 50/60Hz (额定电压)			
最大电压 (23)	110% (额定电压)			
绝缘电阻	≥500MΩ			
线圈功率	DC(W)	约 0.9		
	AC(VA)	约 1.2		
吸合时间 (额定电压)	≤20 ms			
释放时间 (额定电压)	≤20 ms			
初始耐压	同极触点之间	1000VAC/1min (漏电流 1mA)		
	异极触点之间	2000VAC/1min (漏电流 1mA)		
	触点与线圈间	2000VAC/1min (漏电流 1mA)		
环境温度	-55~+70°C			
环境湿度	35%~85%RH			
大气压力	86~106KPa			
耐冲击	10G (正弦半波脉冲: 11ms)			
耐振动	10~55Hz 双振幅: 1.0 mm			
安装方式	插入式			
重量	35g			
认证	CE			
符合标准	继电器符合 IEC61810、底座符合 IEC60947			

## 线圈规格 (23°C)

额定电压 V.DC	12	24	48	110
线圈电阻 -Ω	180	640	2600	13000
额定电压 V.AC	24	48	115	230
线圈电阻 Ω	180	640	4430	16500

注: 线圈电阻公差: 线圈额定电压标称值 110V 以下 1±10%Ω, 110V 以上 1±15%Ω。

## TRN 产品参数

## 基座参数

型号		RSN2S/RSN2M	RSN4S/RSN4M
额定负载	电流	A	12
	电压	V	300
介质耐压	线圈 / 触点	V/S	4000
	触点间	V/S	2500
螺钉扭矩		Nm	> 0.8
外连接导线		AWG/mm 2	20-14/0.5-2.5
使用环境		°C	-40~+85

## 基座参数

型号		RSN2U	RSN4U
额定负载	电流	A	10
	电压	V	300
介质耐压		V/S	2000
螺钉扭矩		Nm	> 0.8
外连接导线		AWG/mm 2	20-14/0.5-2.5
使用环境		°C	-40~+65

## 性能曲线图

## TRN2

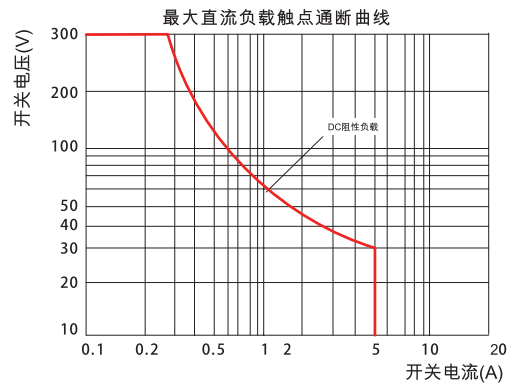
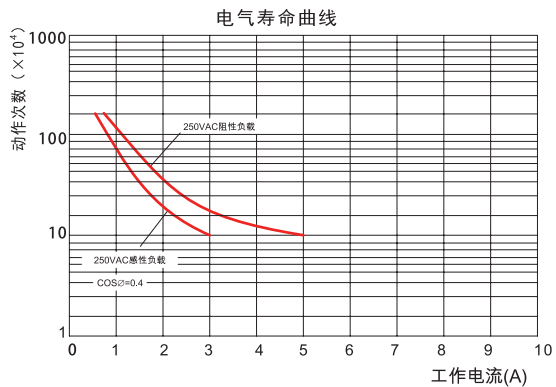

## TRN4

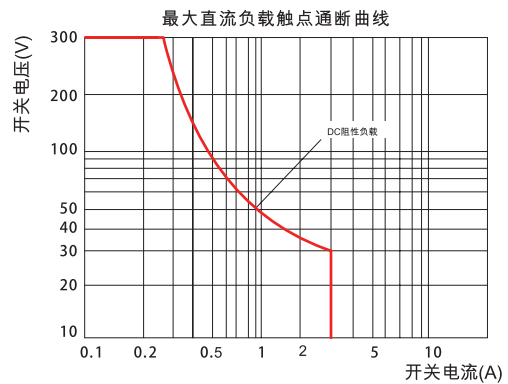
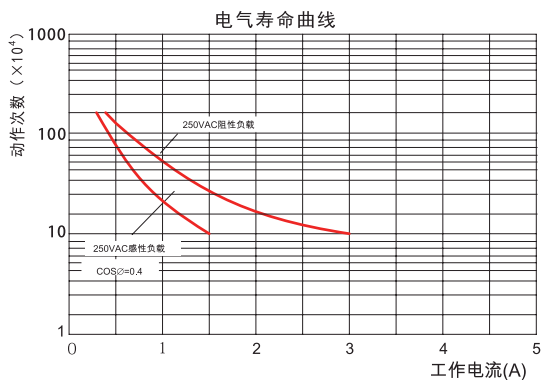

## TRC 产品参数

产品性能				
触点	形式	1C/O	2C/O	
	负载	阻性	12A/250VAC, 30VDC	8A/250VAC, 30VDC
		马达	1/3HP,240VAC	1/6HP,240VAC
	切换功率 (阻性)	3000VA, 360W	2000VA, 240W	
	接触电阻 (初始)	≤50mΩ		
	材料	Ag alloy		
	电气寿命 (频率 1S 通, 1S 断) 高温	≥10 x 10 <sup>4</sup> 次 (1800 Ops/h)		
	机械寿命	≥1000 x 10 <sup>4</sup> 次 (18000 Ops/h)		
吸合电压 (23)	DC: ≤75% (额定电压), AC: ≤80% 50/60Hz (额定电压)			
释放电压 (23)	DC: ≥10% (额定电压), AC: ≥30% 50/60Hz (额定电压)			
最大电压 (23)	110% (额定电压)			
绝缘电阻	≥1000MΩ (500VDC)			
线圈功率	DC(W)	约 0.53		
	AC(VA)	约 1.0		
吸合时间 (额定电压)	≤ 20 ms			
释放时间 (额定电压)	≤ 10 ms			
初始耐压	同极触点之间	1000VAC/1min (漏电流 1mA)		
	异极触点之间	3000VAC/1min (漏电流 1mA)		
	触点与线圈间	5000VAC/1min (漏电流 1mA)		
环境温度	-40~+55°C			
环境湿度	5%~85%RH			
大气压力	86~106KPa			
耐冲击	10G (正弦半波脉冲: 11ms)			
耐振动	10~55Hz 双振幅: 1.0 mm			
安装方式	插入式			
重量	约 18g			
认证	CE			
符合标准	继电器符合 IEC61810、底座符合 IEC60947			

## 线圈规格 (23°C)

额定电压 VDC	12	24	48	110
线圈电阻 Ω	270	1100	4300	22800
额定电压 VAC	24	48	115	230
线圈电阻 Ω	240	1085	6300	23000

注: 线圈电阻公差: 线圈额定电压标称值 110V 以下 1±10%Ω, 110V 以上 1±15%Ω。

## TRC 产品参数

## 底座参数

型号		RSC1U/RSC1S	RSC2U/RSC2S
额定负载	电流	A	16
	电压	V	300
介质耐压	触点间	V/S	2500
螺钉扭矩		Nm	> 0.8
外连接导线		AWG/mm 2	20-14/0.5-2.5
使用环境		°C	-40~+85

## 性能曲线图

## TRC1

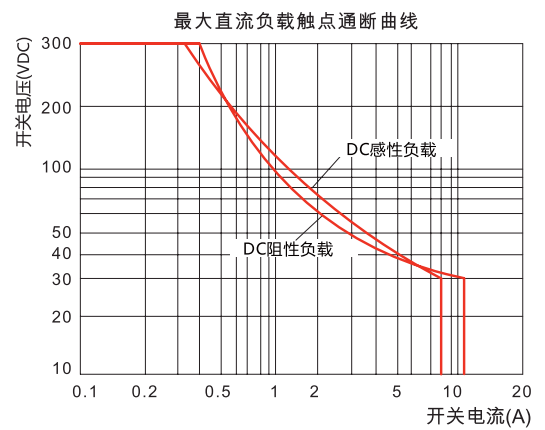
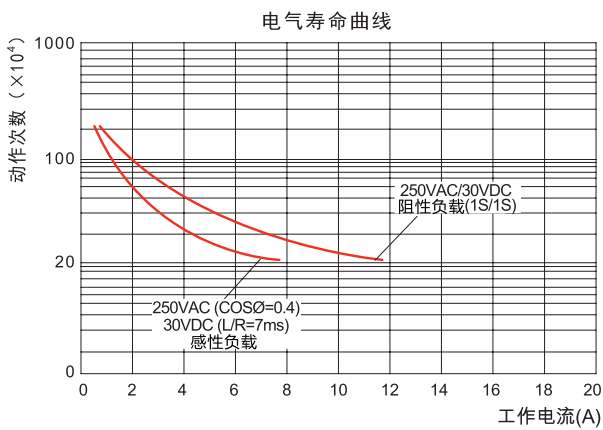

## TRC2

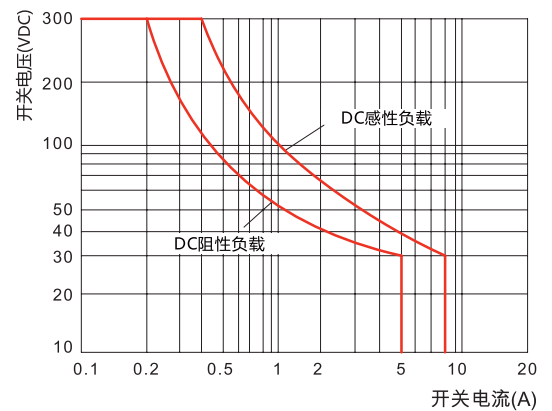
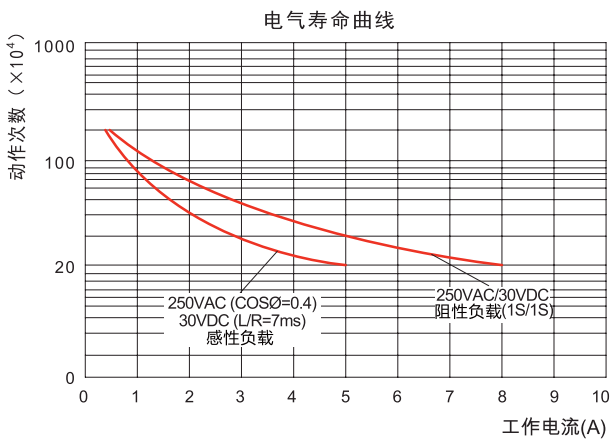

## TRM 型号命名规则说明

TRM	2	D	24	A	*
产品型号	触点数目	控制电压	电压规格	功能定义	特殊要求
↓	↓	↓	↓	↓	↓
TRM	2:2C/O 4:4C/O	A: 交流 D: 直流	012:12V 024:24V 048:48V 110:110V 115:115V 230:230V	A: 全功能型 (机械指示, LED, 测试按钮)	G: 镀金触点

## TRM 产品订货型号

产品	继电器型号	触点数目	控制回路电压	功能描述
	TRM2D012A	2C/O	DC 12V	机械指示, LED, 测试按钮
	TRM2D024A	2C/O	DC 24V	机械指示, LED, 测试按钮
	TRM2D048A	2C/O	DC 48V	机械指示, LED, 测试按钮
	TRM2D110A	2C/O	DC 110V	机械指示, LED, 测试按钮
	TRM2A024A	2C/O	AC 24V	机械指示, LED, 测试按钮
	TRM2A048A	2C/O	AC 48V	机械指示, LED, 测试按钮
	TRM2A115A	2C/O	AC 115V	机械指示, LED, 测试按钮
	TRM2A230A	2C/O	AC 230V	机械指示, LED, 测试按钮
	TRM4D012A	4C/O	DC 12V	机械指示, LED, 测试按钮
	TRM4D024A	4C/O	DC 24V	机械指示, LED, 测试按钮
	TRM4D048A	4C/O	DC 48V	机械指示, LED, 测试按钮
	TRM4D110A	4C/O	DC 110V	机械指示, LED, 测试按钮
	TRM4A024A	4C/O	AC 24V	机械指示, LED, 测试按钮
	TRM4A048A	4C/O	AC 48V	机械指示, LED, 测试按钮
	TRM4A115A	4C/O	AC 115V	机械指示, LED, 测试按钮
	TRM4A230A	4C/O	AC 230V	机械指示, LED, 测试按钮





## TRM 产品订货型号

产品	基座型号	功能描述	接线方式
	RSM2U	优化型	螺钉端子
	RSM4U	优化型	螺钉端子
	RSM2S	分离型	压线框
	RSM4S	分离型	压线框
	RSM2M	混合型	压线框
	RSM4M	混合型	压线框

## TRN 型号命名规则说明

TRN	2	D	24	L	*
产品型号	触点数目	控制电压	电压规格	功能定义	特殊要求
TRN	2:2C/O 4:4C/O	A: 交流 D: 直流	012:12V 024:24V 048:48V 110:110V 115:115V 230:230V	L:LED	G: 镀金触点

## TRN 产品订货型号

产品	继电器型号	触点数目	控制回路电压	功能描述
	TRN2D012L	2C/O	DC 12V	LED
	TRN2D024L	2C/O	DC 24V	LED
	TRN2D048L	2C/O	DC 48V	LED
	TRN2D110L	2C/O	DC 110V	LED
	TRN2A024L	2C/O	AC 24V	LED
	TRN2A048L	2C/O	AC 48V	LED
	TRN2A115L	2C/O	AC115V	LED
	TRN2A230L	2C/O	AC 230V	LED
	TRN4D012L	4C/O	DC 12V	LED
	TRN4D024L	4C/O	DC 24V	LED
	TRN4D048L	4C/O	DC 48V	LED
	TRN4D110L	4C/O	DC 110V	LED
	TRN4A024L	4C/O	AC 24V	LED
	TRN4A048L	4C/O	AC 48V	LED
	TRN4A115L	4C/O	AC115V	LED
	TRN4A230L	4C/O	AC 230V	LED



## TRN 产品订货型号

产品	基座型号	功能描述	接线方式
	RSN2U	优化型	螺钉端子
	RSN4U	优化型	螺钉端子
	RSN2S	分离型	压线框
	RSN4S	分离型	压线框
	RSN2M	混合型	压线框
	RSN4M	混合型	压线框

## TRC 型号命名规则说明

TRC	2	D	24	A	*
产品型号	触点数目	控制电压	电压规格	功能定义	特殊要求
TRC	1:1C/O 2:2C/O	A: 交流 D: 直流	012:12V 024:24V 048:48V 110:110V 115:115V 230:230V	A: 全功能型 (机械指示, LED, 测试按钮) L:LED	G: 镀金触点

## TRC 产品订货型号









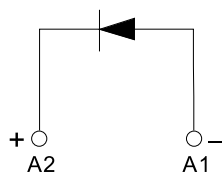
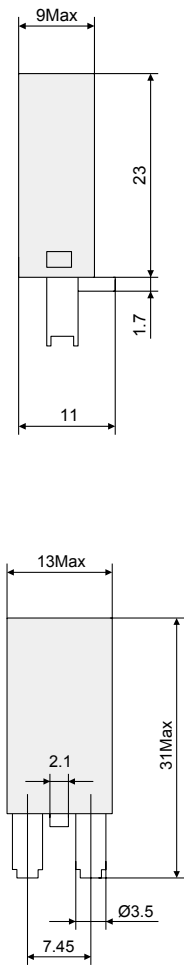

产品	继电器型号	触点数目	控制回路电压	功能描述
	TRC1D012A	1C/O	DC 12V	机械指示, LED, 测试按钮
	TRC1D024A	1C/O	DC 24V	机械指示, LED, 测试按钮
	TRC1D048A	1C/O	DC 48V	机械指示, LED, 测试按钮
	TRC1D110A	1C/O	DC 110V	机械指示, LED, 测试按钮
	TRC1A024A	1C/O	AC 24V	机械指示, LED, 测试按钮
	TRC1A048A	1C/O	AC 48V	机械指示, LED, 测试按钮
	TRC1A115A	1C/O	AC 115V	机械指示, LED, 测试按钮
	TRC1A230A	1C/O	AC 230V	机械指示, LED, 测试按钮
	TRC2D012A	2C/O	DC 12V	机械指示, LED, 测试按钮
	TRC2D024A	2C/O	DC 24V	机械指示, LED, 测试按钮
	TRC2D048A	2C/O	DC 48V	机械指示, LED, 测试按钮
	TRC2D110A	2C/O	DC 110V	机械指示, LED, 测试按钮
	TRC2A024A	2C/O	AC 24V	机械指示, LED, 测试按钮
	TRC2A048A	2C/O	AC 48V	机械指示, LED, 测试按钮
	TRC2A115A	2C/O	AC 115V	机械指示, LED, 测试按钮
	TRC2A230A	2C/O	AC 230V	机械指示, LED, 测试按钮
	TRC1D012L	1C/O	DC 12V	LED
	TRC1D024L	1C/O	DC 24V	LED
	TRC1D048L	1C/O	DC 48V	LED
	TRC1D110L	1C/O	DC 110V	LED

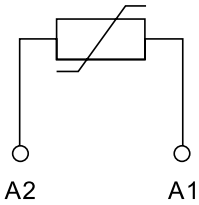
## TRC 产品订货型号

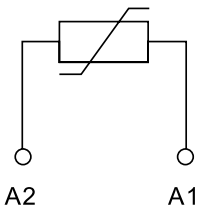
产品	继电器型号	触点数目	控制回路电压	功能描述
	TRC1A024L	1C/O	AC 24V	LED
	TRC1A048L	1C/O	AC 48V	LED
	TRC1A115L	1C/O	AC 115V	LED
	TRC1A230L	1C/O	AC 230V	LED
	TRC2D012L	2C/O	DC 12V	LED
	TRC2D024L	2C/O	DC 24V	LED
	TRC2D048L	2C/O	DC 48V	LED
	TRC2D110L	2C/O	DC 110V	LED
	TRC2A024L	2C/O	AC 24V	LED
	TRC2A048L	2C/O	AC 48V	LED
	TRC2A115L	2C/O	AC 115V	LED
	TRC2A230L	2C/O	AC 230V	LED

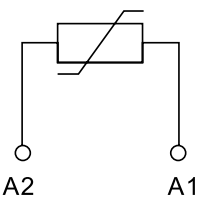
产品	基座型号	功能描述	接线方式
	RSC1U	优化型	螺钉端子
	RSC2U	优化型	螺钉端子
	RSC1S	分离型	压线框
	RSC2S	分离型	压线框

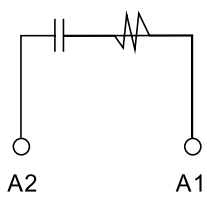
## 附件订货型号

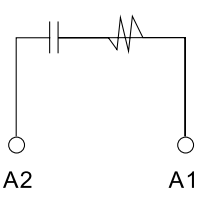
产品	继电器型号	功能描述	适用产品	接线图	尺寸图
	SDG250	防浪涌保护插件 二极管 DC6-250V A2+ A1-	适用于 TRM,TRN,TRC		
	SMG024	防浪涌保护插件 变阻器 DC/AC24V	适用于 TRM,TRN,TRC		
	SMG120	防浪涌保护插件 变阻器 DC/AC120V	适用于 TRM,TRN,TRC		
	SMG240	防浪涌保护插件 变阻器 DC/AC240V	适用于 TRM,TRN,TRC		
	RCG24	防浪涌保护插件 RC 回路 AC6-24V	适用于 TRM,TRN,TRC		
	RCG240	防浪涌保护插件 RC 回路 AC110-240V	适用于 TRM,TRN,TRC		

注：防浪涌保护插件，仅适用于分离型基座，优化型和混合型基座不适用

## 附件订货型号

产品	继电器型号	功能描述	适用产品
	SCG07	金属紧固卡扣 (适用于优化型基座)	适用于 TRM,TRN
	SCG02	金属紧固卡扣 (适用于混合 / 分离型基座)	适用于 TRM,TRN
	SCG06	塑料紧固卡扣 (适用于混合 / 分离型基座)	适用于 TRM,TRN
	SLG02	标示牌 (适用于混合 / 分离型基座)	适用于 TRM,TRN
	TRCSLG01	TRC 标识板 (适用于分离型基座)	适用于 TRC
	TRCSCG01	TRC 塑料扳扣 (适用于分离型基座)	适用于 TRC
	TRCSQG01	TRC 连接桥 (适用于分离型基座)	适用于 TRC
	SZG01	TR 继电器标签纸 订货单位: 1 卷 (1000 张 / 卷)	适用于 TRM,TRN,TRC

注: 标签纸 SZG01 接受印字定制, 默认颜色为黄底黑字 (中文: 微软雅黑, 英文: Arial, 最多两个中文字符或四个英文字符)。需下单时详询天逸电器商务部。

## TRM 产品外形图尺寸

## 外形图尺寸 (mm)

TRM2

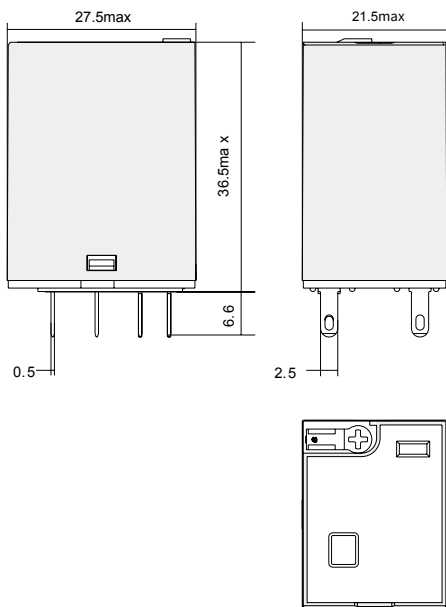

TRM4

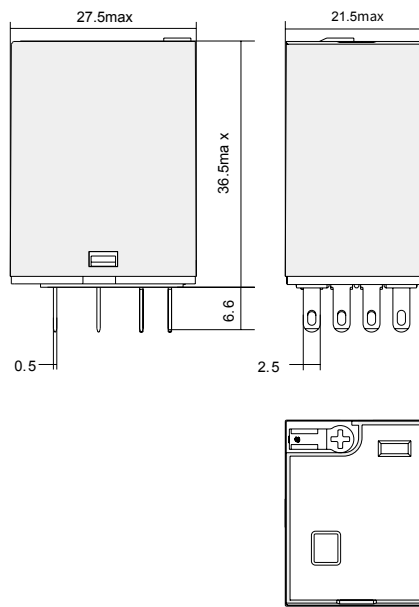

## 接线图

TRM2

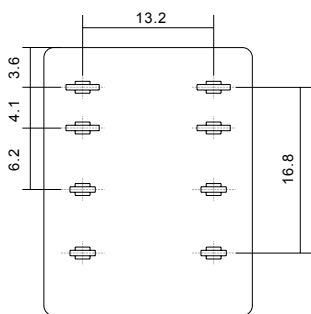

DC

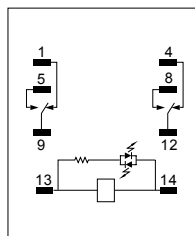

AC

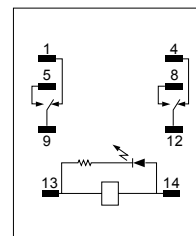

TRM4

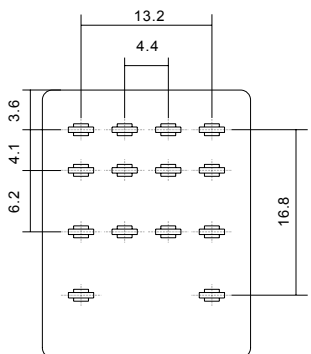

DC

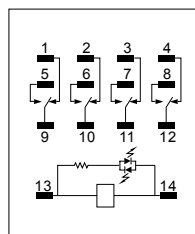

AC

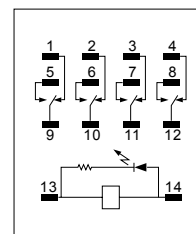

# TRM 产品外形图尺寸

## 底座图尺寸 (mm)

RSM2M

RSM4M

RSM2S

RSM4S

RSM2U

RSM4U

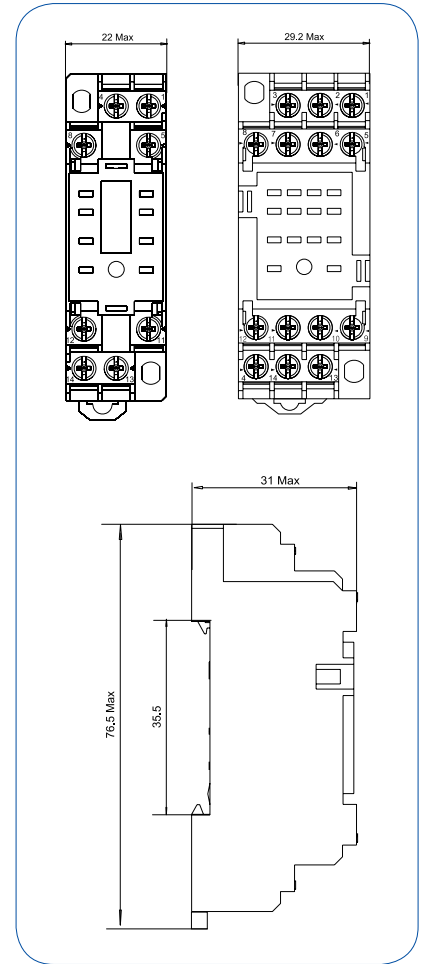
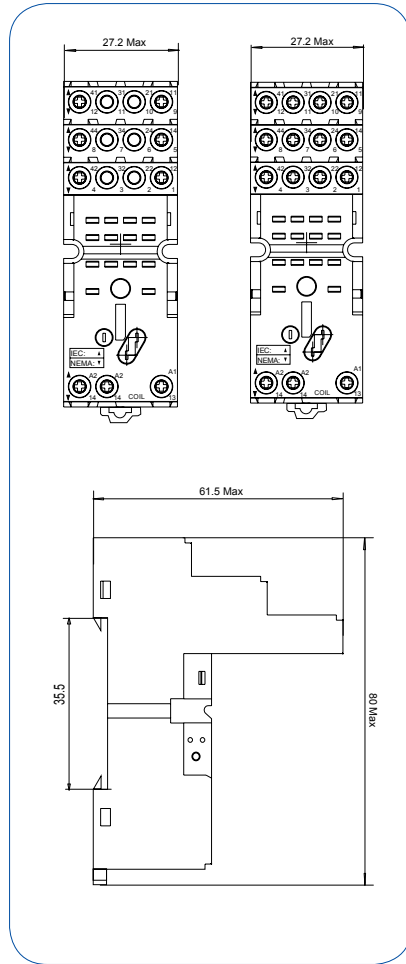
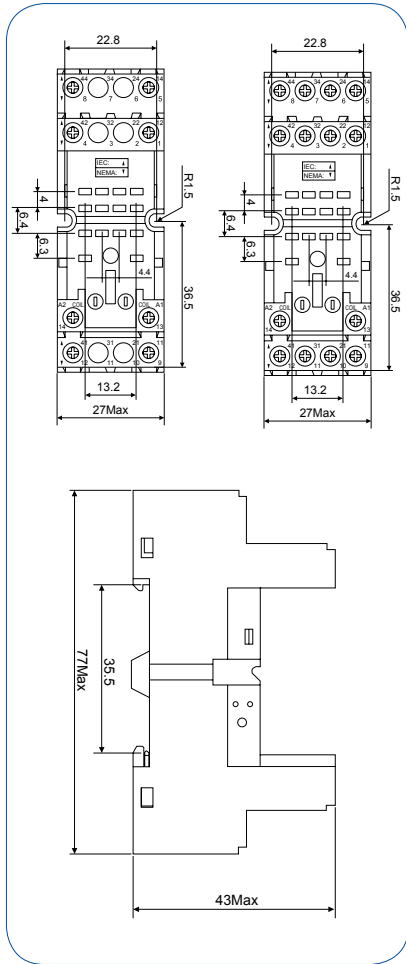

## 端子配置内部连接

RSM2M

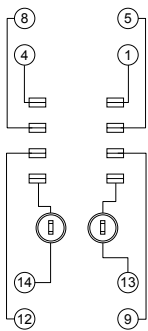

RSM4M

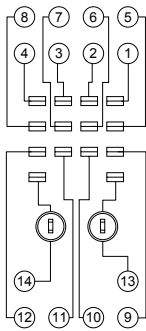

RSM2S

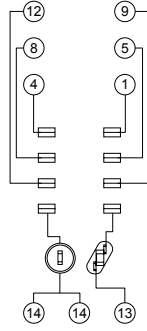

RSM4S

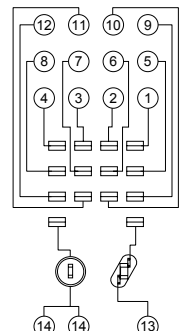

## TRN 产品外形图尺寸

## 外形图尺寸 (mm)

## TRN2

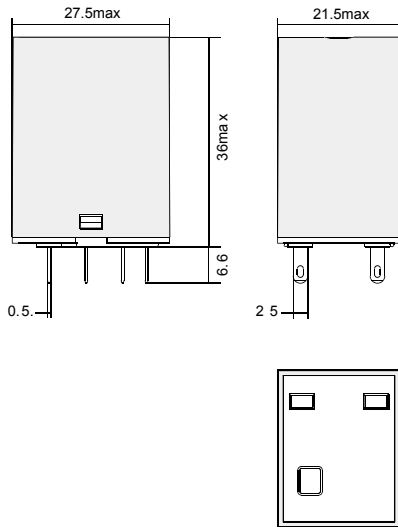

## TRN4

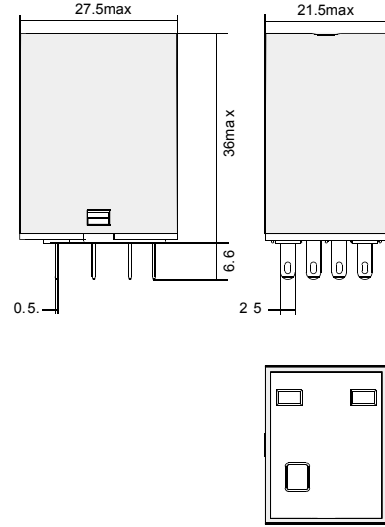

## 接线图

## TRN2

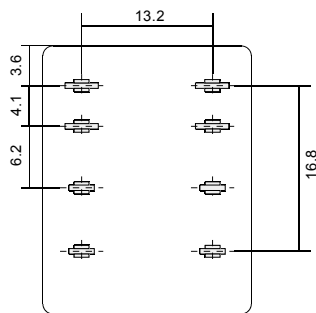

DC

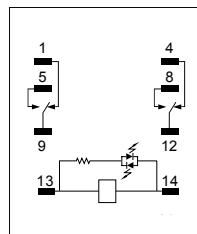

AC

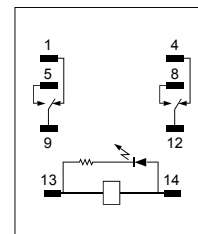

## TRN4

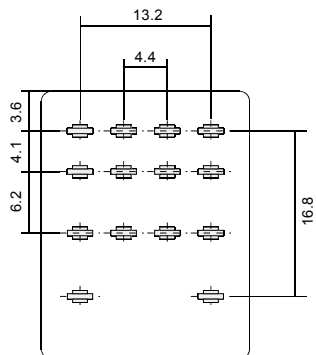

DC

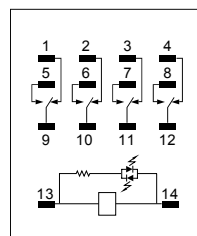

AC

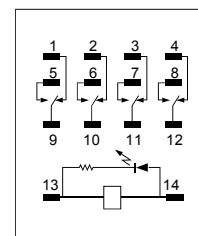



# TRN 产品外形图尺寸

## 基座图尺寸 (mm)

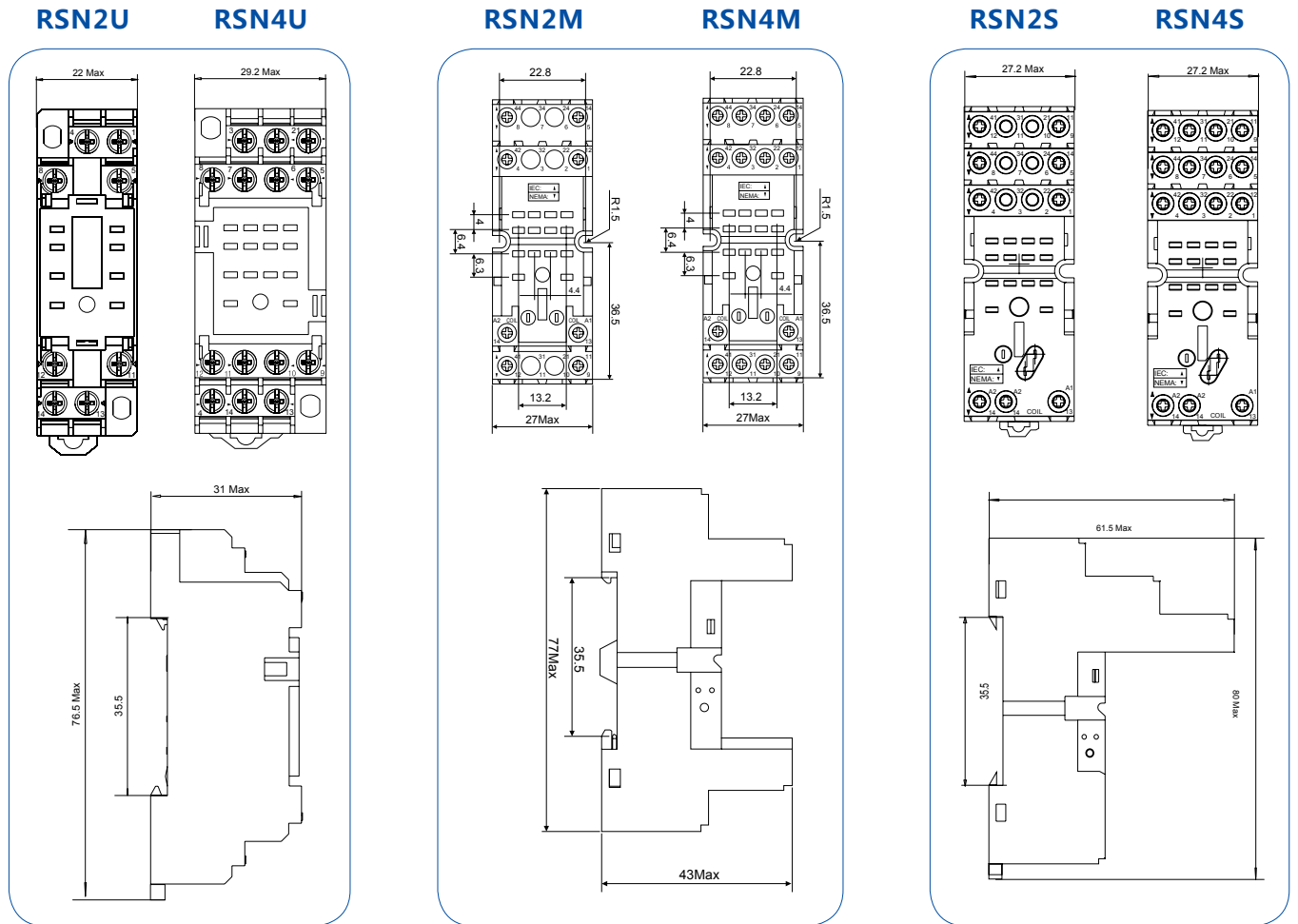

## 端子配置内部连接

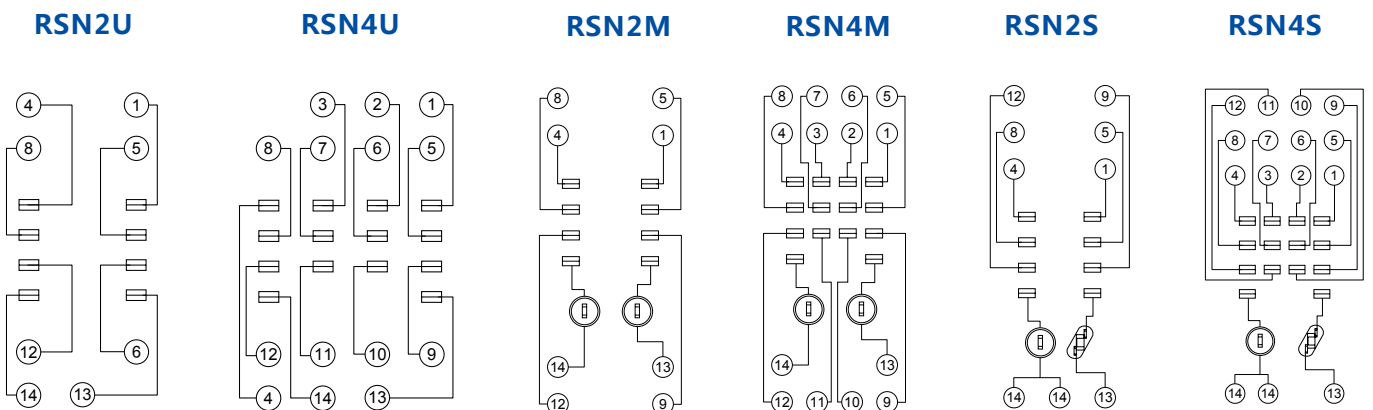

# TRC 产品外形图尺寸

## 外形图尺寸 (mm)

TRC1

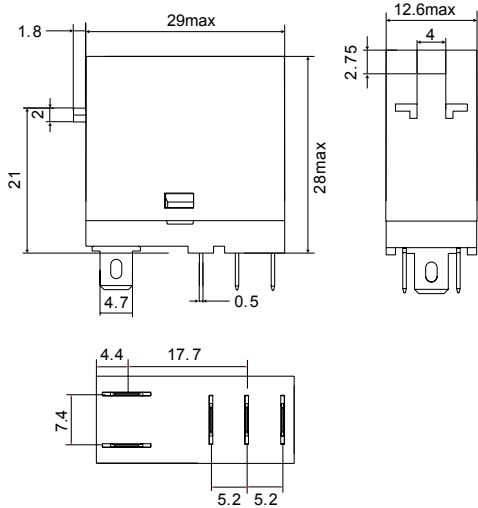

TRC2

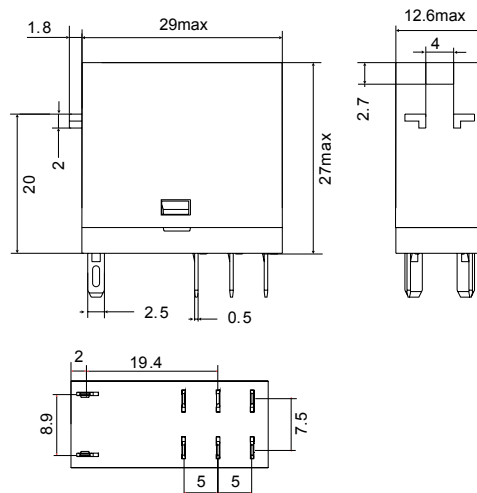

TRC1-L

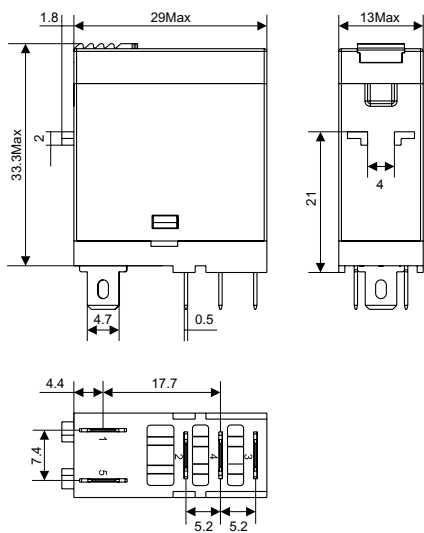

TRC2-L

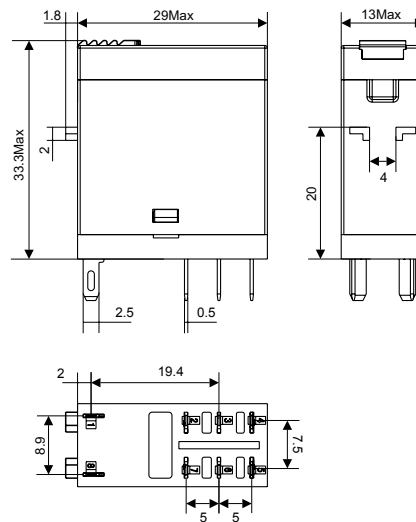

## 接线图

TRC1 AC

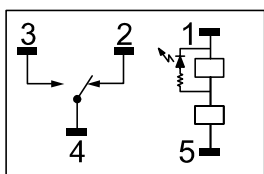

TRC1 DC

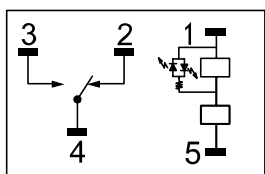

TRC2 AC

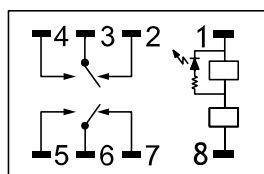

TRC2 DC

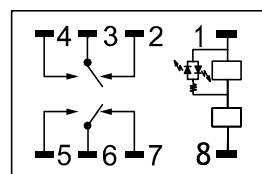

## TRC 产品外形图尺寸

### 底座图尺寸 (mm)

RSC1S



RSC2S

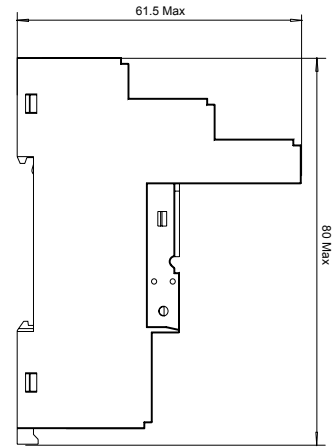

RSC1U

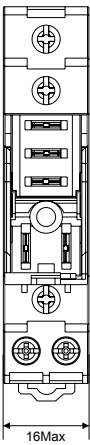

RSC2U

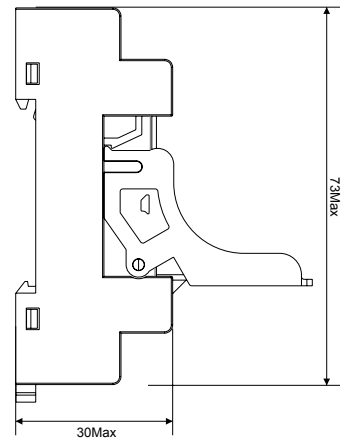
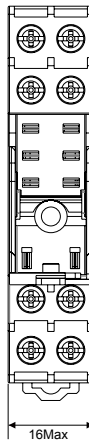

### 端子配置内部连接

RSC1S

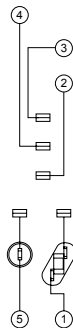

RSC2S

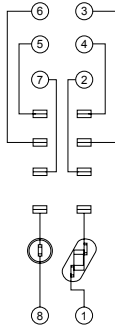

RSC1U

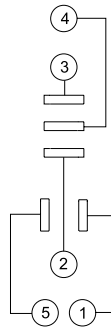

RSC2U

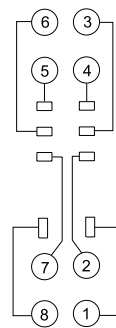

本样本中提供的信息只是对产品的一般说明和特性介绍。文中内容可能与实际应用的情况有所出入，并且可能会随着产品的进一步开发而发生变化

如有变动，恕不事先通知  
最新样本以官网下载为准，如有特殊，请与我司联系



更多产品资料信息，请到官网下载电子资料。  
感谢您为节能环保做出的贡献！

## 上海天逸电器有限公司

地址：上海市松江区北闵路101号 邮编：201611  
电话：86-21-57776240  
<http://www.tayee.com.cn>

服务热线：**400 820 4217**

2019/06-01CN

微信服务号

